

Tool Heaters and Temperature Controllers



30 years of precision process temperature control

Tool Heaters and Temperature Controllers

Tricool Thermal is proud to have been manufacturing precision process temperature control equipment in the UK for over 30 years and we have built our reputation on this.

We are supported and controlled by our ISO 9001 accreditation within our UK based design, engineering and production facility - to exacting CE standards.

We remain at the forefront of the industry in developing scalable, cost effective 'off the shelf' and bespoke solutions with a heating temperature range of up to 350°C.

We have extensive experience in providing solutions worldwide, including Africa, the Middle East and Asia.



We offer standard heaters and temperature control units from stock or can purpose build a unit to meet your specific site requirements:

Entry level units - (6kW) providing reliable temperature control in compact units at a very low price/feature ratio.

Water Heaters - (9-96kW) offering temperatures up to 95°C and designed for food production processes, chemical and pharmaceutical applications, including jacketed vessels.

Oil Heaters - (9-96kW) offering temperatures up to 350°C, suitable for extrusion and die casting..

Pressurised water heaters - (9-96kW) offering temperatures up to 160°C, suitable for injection moulding.

Custom built units - including ATEX approved heating units, oil skids and close control tolerances. Available from 3kW up to 400kW and offering temperatures up to 350°C.

Rental equipment - we can offer you a temporary unit to manage breakdowns or short-term R&D trials and non-capital funded projects.

Installation and service - we have a nationwide team of engineers providing 24/7 cover.



Standard Heating Product Ranges

Fluid Type	Units	Max Temp °C	Min Heating kW	Max Heating kW	Min Cooling kW	Max Cooling kW	Upper Max Flow /Bar	Max Connections process	Max Connections Cooling	Min FLA Amps	Max FLA Amps
Entry level Water	T90e	95	-	6	-	40	40/4.0	1/2"	1/2"	-	10
Water	T90	95	18	96	33	90	220/3.0	1 1/2"	1"	32	150
Pressurised Water	P140	140*	9	96	30	140	220/3.2	1 1/2"	1"	18	155
Oil or Water	HFT150s/T90s	150/95	9	96	100	-	600/3.5	3/4"	1/2"	18	30
Oil	HFT200/350	350	9	18	18	35	70/6.0	2"	1'	20	155

* option up to 160

Why Tricool Thermoregulators?

Our standard units come with many beneficial equipment features:

Stainless steel heat exchangers - large gaps between the plates reduce the risk of blocking due to contamination and help increase efficiency.



Non ferrous internal parts - helping to keep the systems clean, with no rust from the units internal components.



Direct acting self cleaning solenoid valves - helping reduce the maintenance needed, due to minimal manual cleaning required.

**not available on the T90e*



Solid state relay - energy saving due to pulsing every 0.3 seconds (contactors generally do every 16 seconds). These also offer increased accuracy and with no moving parts, wear and tear is eliminated.

**not available on the T90e*

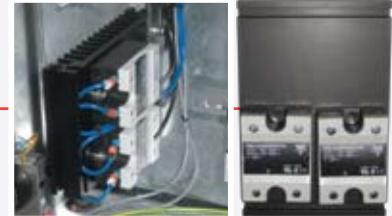

Standard diagnostic controller - helps with unit maintenance and serviceability showing details of any faults that may occur.

Optional controller - with a 3.5" colour screen we also offer a 50MB controller to provide customer configurable data recording for bespoke, in-depth analysis of process temperatures; ideal for automotive, pharmaceutical and food industries.



Castors - enables easy manoeuvrability of the units.



Easy to use control panels - as our interfaces guide users through processes, setting and controlling temperature is a breeze. No specialised certification is needed to operate and production staff can be easily trained to use them, production line productivity can be improved.



Optional Tailored Features:

- Switchable remote and local sensing
- IP55 rated electrical specification
- Stainless steel panels
- Direct cool
- Controller available with a number of language chips
- Various flow/pressure options
- Increased cooling
- Bespoke machines built to order

These high quality efficient units deliver consistently higher temperatures without pressurisation.

Common industrial applications are:

Plastics Extrusion, Die Casting, Injection Moulding, higher temp Food Production processes, Chemical and Pharmaceutical applications, high temp Jacketed Vessels.

In addition to the standard features these units include:

- 1. Magnetic drive pump on units over 200°C**
A seal-less pump, that alleviates any leaks and helps reduce maintenance needed.
- 2. Low volume tank**
For higher temperature (200°C+), this individual tubular heater tank reduces the liquid volume in circulation and results in reduced power input needed for heating.
- 3. Large volume tank**
Enabling more stable mid range temperatures, up to 150°C.



HTF200 & 350
Flow Diagram

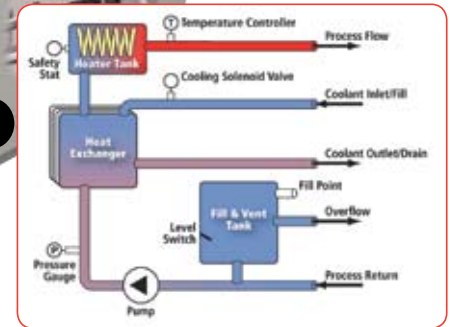

HTF150s
Flow Diagram

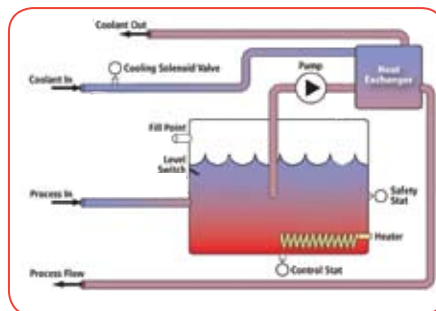

UNIT SPECIFICATIONS

Model	Heating kW	Standard kW Cooling	Max Flow/Pressure LPM/bar		Connections Process		Connections Cooling		FLA Amps	
			HTF200	350	HTF200	350	HTF200	350	HTF200	350
HTF200/350 - 9	9	60	50/3.6	58/4.6	1"	1/2"	1/2"	3/4"	18	20
HTF200/350 - 12	12	60	50/3.6	70/7.5	1"	1/2"	1/2"	3/4"	22	24
HTF200/350 - 18	18	60	100/2.6	100/6	1"	1 1/4"	1"	1"	32	37
HTF200/350 - 24	24	60	100/2.6	100/6	1"	1 1/4"	1"	1"	40	48
HTF200/350 - 36	36	100	200/2.9	180/7	1"	1 1/2"	1"	1"	55	65
HTF200/350 - 48	48	100	200/2.9	180/7	1 1/2"	1 1/2"	1"	1"	75	84
HTF200/350 - 54	54	100	200/2.9	700/3	1 1/2"	2"	1"	1"	89	95
HTF200/350 - 72	72	100	290/2.8	700/3	2"	2"	1"	1"	110	120
HTF200/350 - 96	96	100	290/2.8	700/3	2"	2"	1"	1"	150	155

Model	Heating kW	Heat Exchanger 80°C TD	Max Flow/Pressure LPM/bar	Connections Process	Connections Cooling	FLA Amps	Dimensions mm
HTF150s - 9	9	44KW	60/4	1/2"	1/2"	18	630 L x 300 W x 670 H
HTF150s - 12	12	44KW	60/4	1/2"	1/2"	22	630 L x 300 W x 670 H
HTF150s - 18	18	44KW	70/6	3/4"	1/2"	30	630 L x 300 W x 670 H

These pressurised units deliver high temperature water heating with limited need for maintenance and offer increased energy efficiency.

Common industrial applications are:

Plastics/Injection Moulding, Food Production processes, Chemical and Pharmaceutical applications and Jacketed Vessels.

In addition to the standard features these units include:

1. Low volume tank

Low volume individual tubular heater tanks, which reduce the liquid volume in circulation, resulting in a reduced power input required for heating.

2. Air release bottle

Protects the heating elements and pump where large amounts of air could be present.

3. Auto shutdown system

If a pipe breaks the machine will stop and lock down the water supply system - to prevent any leaks.

4. Pressure sustaining accumulator

Reduces the use of pressure relief valves.



P140 Flow Diagram

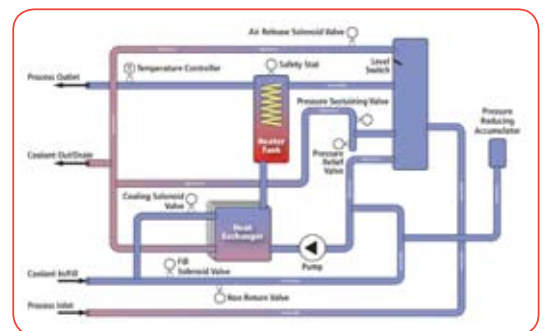

UNIT SPECIFICATIONS

Model	Heating kW	Standard kW Cooling 120°C TD	Max Flow/ Pressure LPM/bar	Connections Process	Connections Cooling	FLA Amps	Dimensions mm
P140 - 9	9	30	40/3.8	1/2"	1/2"	18	630 L x 300 W x 670 H
P140 - 12	12	30	40/3.8	1/2"	1/2"	22	630 L x 300 W x 670 H
P140 - 18	18	70	70/4.0	1"	3/4"	32	750 L x 360 W x 920 H
P140 - 24	24	70	70/4.0	1"	3/4"	40	750 L x 360 W x 920 H
P140 - 36	36	70	130/3.0	1 1/4"	1"	55	1000 L x 500 W x 1180 H
P140 - 48	48	100	130/3.0	1 1/4"	1"	76	1000 L x 500 W x 1180 H
P140 - 54	54	100	130/4.0	1 1/2"	1"	89	1400 L x 600 W x 1300 H
P140 - 72	72	100	130/4.0	1 1/2"	1"	106	1400 L x 600 W x 1300 H
P140 - 96	96	100	220/3.2	1 1/2"	1"	155	1400 L x 600 W x 1300 H

These non pressurised units deliver highly effective water heating with high reliability and offer increased energy efficiency.

Common industrial applications are:

Plastics/Injection Moulding, Food Production processes, Chemical and Pharmaceutical applications, Jacketed Vessels.

In addition to the standard features these units include:

1. Low volume tank

Low volume individual tubular heater tanks, which reduce the liquid volume in circulation, resulting in a reduced power input required for heating.

2. Leakstopper on the T90s

Standard feature that enables the operator to stop minor leaks and carry on production.

3. Large volume tank on T90s

Enabling more stable mid range temperatures.



T90s Flow Diagram

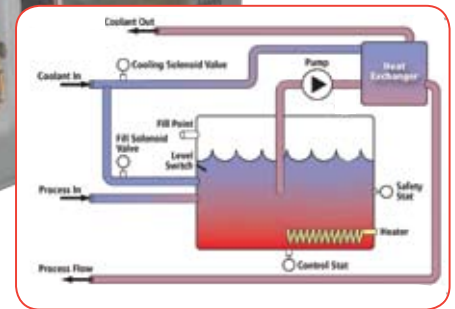

T90 Flow Diagram

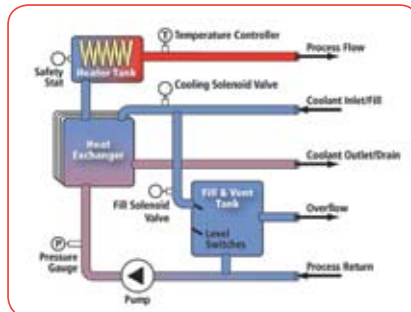

UNIT SPECIFICATIONS

Model	Heating kW	Standard kW Cooling	Max Flow/ Pressure LPM/bar	Connections Process	Connections Cooling	FLA Amps	Dimensions mm
T90 - 18	18	33	70/4.0	1"	3/4"	32	750 L x 360 W x 920 H
T90 - 24	24	33	70/4.0	1"	3/4"	40	750 L x 360 W x 920 H
T90 - 36	36	41	130/3	1 1/4"	1"	55	1000 L x 500 W x 1180 H
T90 - 48	48	41	130/3	1 1/4"	1"	76	1000 L x 500 W x 1180 H
T90 - 54	54	41	130/4	1 1/2"	1"	89	1400 L x 600 W x 1300 H
T90 - 72	72	41	130/4	1 1/2"	1"	106	1400 L x 600 W x 1300 H
T90 - 96	96	70	220/3.2	1 1/2"	1"	150	1400 L x 600 W x 1300 H
T90s - 9	9	44kW	60/4	1/2"	1/2"	18	630 L x 300 W x 670 H
T90s - 12	12	44kW	60/4	1/2"	1/2"	22	630 L x 300 W x 670 H
T90s - 18	18	44kW	70/6	3/4"	1/2"	30	630 L x 300 W x 670 H

This easy to control, compact and reliable unit offers a highly cost effective temperature control option.

Common Industrial applications are:

Plastics / Injection Moulding, Food Production processes, Chemical and Pharmaceutical applications.

In addition to the standard features these units include:

1. **Microprocessor control**
Uses intelligent P.I.D control of heating and cooling to maintain set-point accuracy.
2. **Unique, purpose built reversible pump**
Stops leaks instantly. In the event of a leak developing, the pump can be switched to reverse. This creates a vacuum in the system and allows the run to be finished before the leak is rectified.
3. **Safety features**
Include automatic level control, motor protection overload, digital regulator preset at maximum working temperature and additional adjustable thermostat.
4. **Corrosion free construction**
With major components manufactured from stainless steel, brass or phosphor bronze.



Equipment fitted as standard on the T90e:

- P.I.D twin digital readout controller
- Low level switch
- Auto fill solenoid valve
- Cooling solenoid valve
- Safety stat
- 3 metre complete with 16amp phase changeover plug (for leakstopper mode)

EC Directive compliance:

- Machinery
- Low Voltage
- EMC



UNIT SPECIFICATIONS

Heating Capacity	6kW
Max Operating Temperature	95 °C/90 °C Leakstopper
Heater Control	Contactur
Cooling System	Indirect stainless steel plate
Capacity	40kW at 70 °C TD
Pump Type	Centrifugal
Max Flow/Pressure	40 l/m/4bar
Model	T401/110
Electrical Supply	400v-3ph-50hz + N + E
Control	230v
Frame Model	M1
Length	530mm
Width	250mm
Height	430mm
Connections	Process 1/2" BSP Cooling 1/2" BSP
Weight	25Kgs
Colour	Red/Grey
FLA	10

Call Tricool Thermal free on 0800 977 5709
or email us at info@icstemp.com



tricolothermal
HEATING & COOLING

Group Companies

Head Office South

ICS House
Stephenson Road
Calmore Industrial Estate
Totton, Southampton
SO40 3RY

Freephone 0800 977 5709
T +44 (0)23 8052 7300
F +44 (0)23 8042 8366

London

Kingsbury House
468 Church Lane, Kingsbury
London, NW9 8UA
T +44 (0)208 200 2404
F +44 (0)23 8042 8366

Midlands

Birmingham Science Park Aston
Faraday Wharf
Holt Street, Birmingham, B7 4BB
T +44 (0)121 326 7771
F +44 (0)121 327 4114

North

Floor 3, Caspian House
East Parade
Little Germany
Bradford, BD1 5EP
T +44 (0)1274 740877
F +44 (0)1274 391708

Scotland

Unit 5, 53/58 South Avenue
Blantyre Industrial Estate
Blantyre, G72 0XB
T +44 (0)1698 723308
F +44 (0)1698 723309

Ireland

T +353 (0)86 38 77990
F +44 (0)1274 391708

Distributor - Non Plastics

Mac Technologie

Zac du Frégy III
1, Rue Marguerite Perey
77610 Fontenay Tresigny
France
T +33 01 64 06 42 42

Distributor - Plastics

Farpi-France

5, rue Marius Berliet
Z.I. le Chanay - BP 3-F-69720
St Bonnet de Mure (France)
T +33 (0)4 78 40 81 32
F +33 (0)4 78 40 79 73

